

V-200U
V-400U
V-500U
V-650U
V-800U

Five-axis Machining Center

High speed High precision High efficiency

Taikan

HIGH-END INTELLIGENT EQUIPMENT TURN-KEY SOLUTION SERVICE PROVIDER



Features and Technologies

Structure and configuration

Optional and highlights

parameter and dimension

Five-axis Machining Center

V-200U/V-400U

- ★ German technology plus high-precision DD direct drive rotarytable, original imported Siemens 5-axis CNC system
- ★ Combining industrial design elements and human-machine interaction considerations, the overall appearance design of the machine is aesthetically pleasing and has a neat and reasonable layout of operating positions, enhancing the human-machine interaction experience



High speed
High precision
High efficiency



Hollow mesh wisdom ball

Diversified application fields

Impellers, Precision moulds, Medical device, Automated parts, Aerospace parts, Die casting



Three-way pipe



Booster impeller

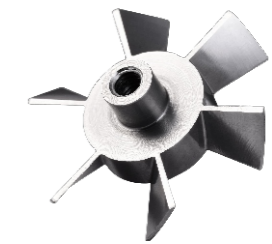

Stainless steel small impeller



Benz parts



Meteor hammer



Micro hole parts

Five-axis Machining Center

Technical Description of Equipment Structure

- ★ The main structure adopts portal O-shaped structure with high rigidity, the distance from spindle to cross beam is short, the structural design layout of B/C axis rotarytable is reasonable, and the lathe bed is made of high-quality gray cast iron material, which has the characteristics such as small overall stress and deformation and strong vibration resistance;
- ★ Combined with modern finite element analysis software, the rigidity of the main structure of the lathe bed is continuously optimized to achieve the optimal design;
- ★ German technology plus high precision DD direct drive rotarytable, high-rigidity rotarytable body structure, driven by torque motor, matched with high-resolution encoder, and the rotarytable is designed with reasonable cooling channel to ensure the transmission accuracy and stability;

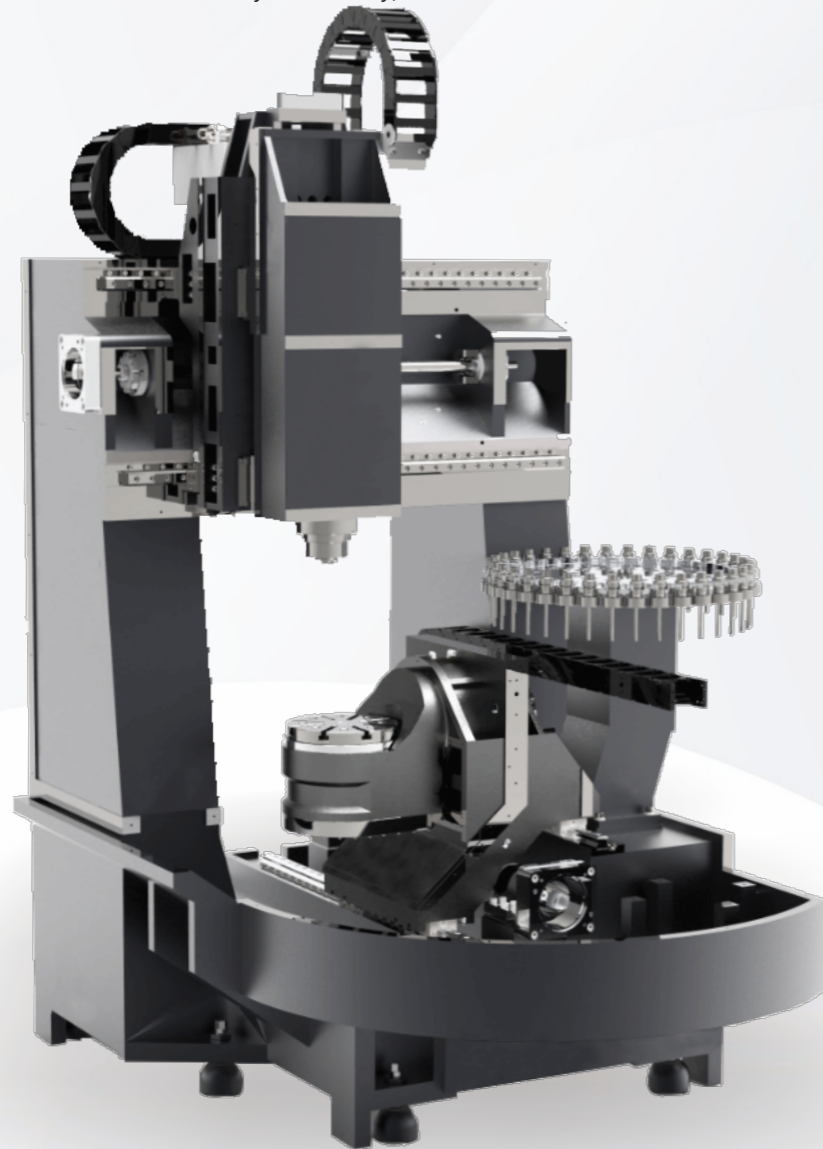

Five-axis Machining Center

Upmarket and safe processing configurations



V-200U: Configured with 30T umbrella-shaped tool magazine

- ▶ Maximum tool length: 150mm
- ▶ Maximum diameter : $\Phi 40\text{mm}/\phi 60\text{mm}$ (full magazine/vacant adjacent slot)
- ▶ Maximum tool weight: 1.2kg

V-400U: Configured with 24T umbrella-shaped tool magazine

- ▶ Maximum tool length: 200mm
- ▶ Maximum diameter : $\Phi 50\text{mm}/\phi 100\text{mm}$ (full magazine/vacant adjacent slot)
- ▶ Maximum tool weight: 2kg

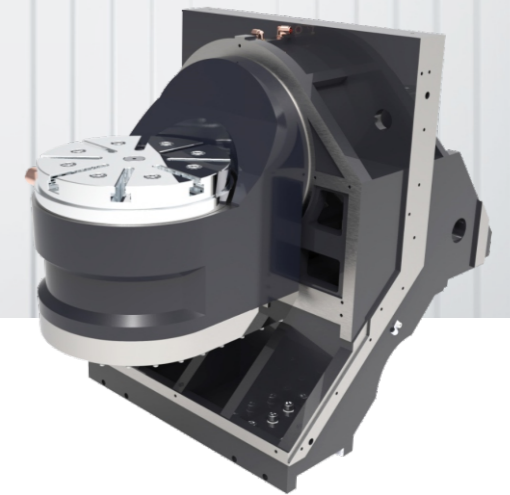

German technology plus high precision direct drive turntable

- 1** The B/C axis of the turntable is designed with a cast iron structure, which greatly improves its rigidity and seismic resistance
- 2** The B/C axis is equipped with a large torque frameless direct drive motor, with a compact structural design. The motor rotor is integrated with the rotary mechanism of the turntable, providing excellent transmission rigidity
- 3** The outer stator of the motor is cooled with coolant to ensure the thermal stability of the turntable
- 4** The maximum speed of B/C axis can reach 50r/min

Five-axis Machining Center
V-200U Optional spindle model

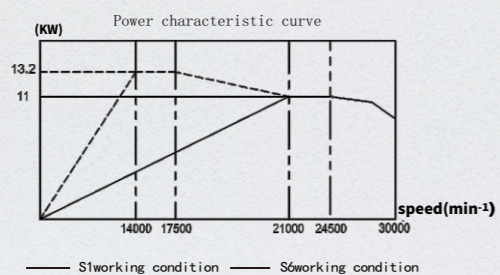
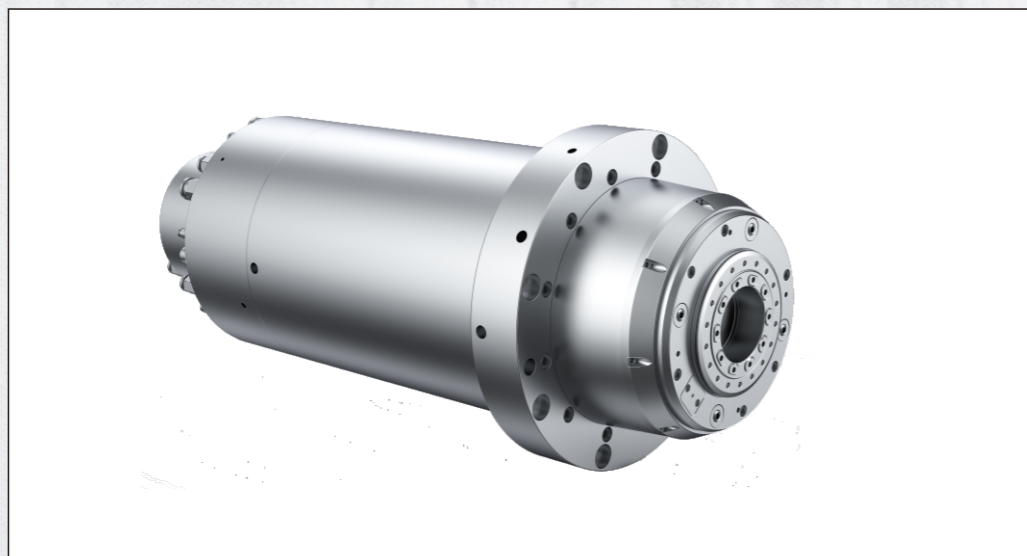

HSK E40 30000RPM 11/13KW 5/8.7Nm

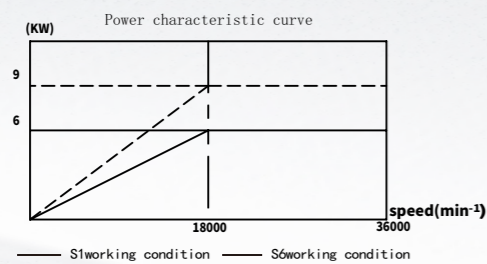
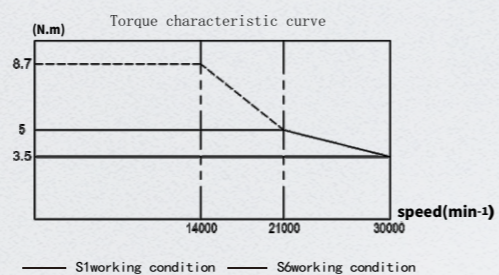

HSK E32 36000RPM 6/9KW 3.1/4.8Nm

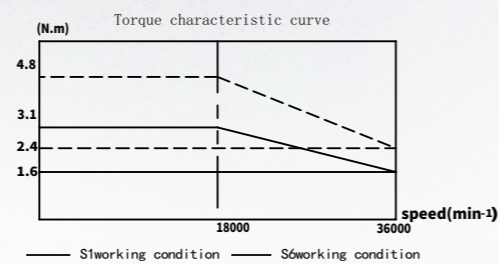

Five-axis Machining Center
V-400U Optional spindle model

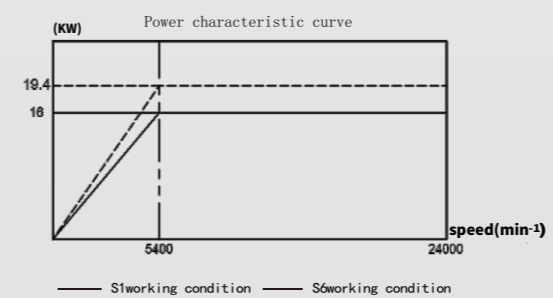

HSK E50 24000RPM 16/19KW 28/34Nm

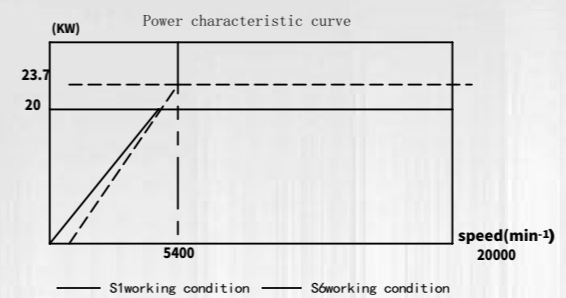
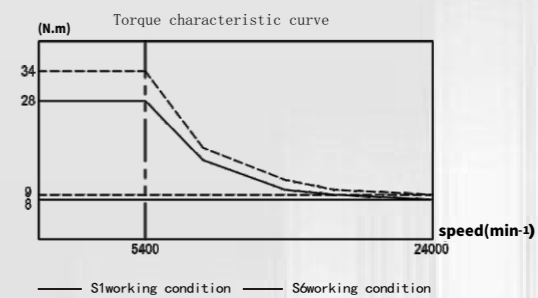

HSK A63 20000RPM 20/23.7KW 35/42Nm

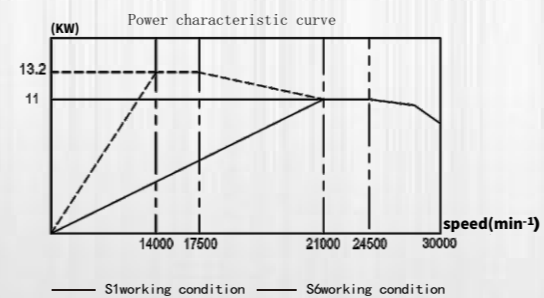
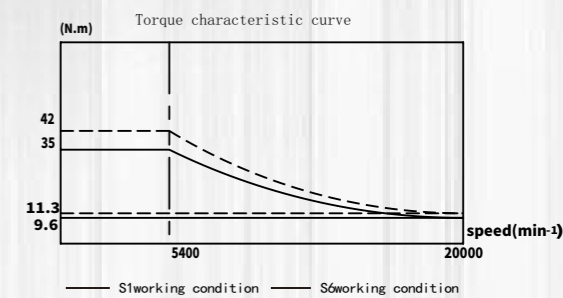

HSK E40 30000RPM 11/23.7KW 5/8.7Nm

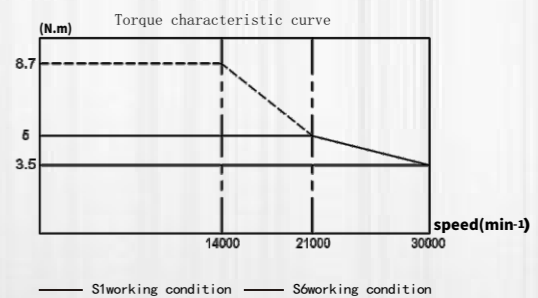

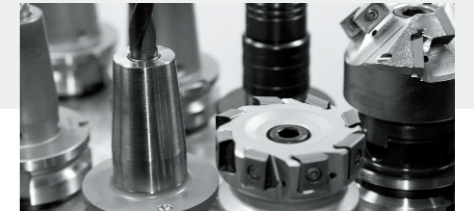

Technical Parameters

		V-200U	V-400U
Stroke X/Y/Z	mm	500/280/300	700/450/400
B-axis Rotation range	°	+30~ -120	+30~ -120
C-axis Rotation range	°	360	360
Distance from spindle nose to worktable	mm	100-400	100-500
Worktable size	mm	φ260	φ420
Maximum load of the workbench	kg	30	150
T-slot (number of slots - slot width*spacing)	mm	8-14*45°	8-14*45°
X/Y/Z-axis Fast moving speed	mm/min	24000	24000
B/C-axis Rapid rotation speed	r/min	50/50	50/50
X/Y/Z-axis Positioning accuracy	mm	0.006/0.006/0.006 (VDI 3441)	0.006/0.006/0.006 (VDI 3441)
X/Y/Z-axis Repeated positioning accuracy	mm	0.004/0.004/0.004 (VDI 3441)	0.004/0.004/0.004 (VDI 3441)
B/C-axis Positioning accuracy	sec	8/8 (VDI 3441)	5/5 (VDI 3441)
B-C-axis Repeated positioning accuracy	sec	5/5 (VDI 3441)	3/3 (VDI 3441)
Spindle motor power	kW	11/19	16/19.4
Spindle motor torque(S1/S6)	N.m	5/8.7	28/34
Spindle speed	r/min	0~30000	0~24000
Spindle taper	/	HSK E40	HSK E50
Tool magazine structure	/	Umbrella-shaped tool magazine	Umbrella-shaped tool magazine
Tool magazine capacity	T	30	24
Maximum tool weight	kg	1.2	2
Maximum tool length	mm	150	200
Maximum diameter (full magazine/vacant adjacent slot)	mm	φ40/φ60	φ50/φ100
CNC system	/	SiemensSINUMERIK ONE	SiemensSINUMERIK ONE
Overall dimension of lathe (L*W*H)	mm	3200*4000*2700	3600*4200*3200

All pictures and parameter configurations in this album are for reference only. The products delivered shall prevail. Our products are being constantly upgraded, and the above information is subject to change without prior notice.

Technical configuration

	V-200U	V-400U
Cast iron housing	●	●
THK/INA roller guide rail	●	●
NSK high-speed screw (with hollow cooling or nut cooling)	●	●
DD direct drive turntable	●	●
Full protection under sheet metal cover	●	●
Intelligent operation panel (a 18.5" display)	●	●
HSK E32 high-speed motorized spindle 36000rpm	○	▲
HSK E40 high-speed motorized spindle 30000rpm	●	○
HSK E50 high-speed motorized spindle 24000rpm	△	●
HSK E63 motorized spindle 20000rpm	△	○
24T tool magazine	○	●
30T tool magazine	●	▲
36T tool magazine	▲	▲
Frequency conversion water cooler with temp. of ±0.1° (spindle, rotarytable, screw)	●	●
Electric cabinet A/C	●	●
Scraper chip conveyor	●	●
Drum scraper chip conveyor	○	○
Chain plate chip conveyor	○	○
Automatic lubricating system	●	●
Gas circuit system	●	●
LED work light	●	●
Tricolor warning light	●	●
Safety door lock	●	●
External hand wheel	●	●
Power failure back-off protection device	●	●
Tool cutting & cooling system	●	●
In-machine chip flushing system	●	●
Air gun	●	●
Water gun	●	●
Siemens SINUMERIK ONE Five axis control system	●	●
HEIDENHAIN TNC640 Five axis control system	○	○
Linear grating rulers for three axes	○	○
BLUM setting gauge-setter	○	○
HEXAGON setting gauge-setter	○	○
Automatic calibration system of slewing center (Renishaw OMP400 probe, standard ball and calibration system)	○	○
Anti-collision system	○	○
Oil mist collector	○	○
Oil-gas lubricating system of spindle	○	○
CTS 2/3/5/7MPa	○	○
Virtual Lathe and Simulation System	○	○

● Standard configurations ○ Optional configuration ▲ Consultation required △ Not Supported

Machine range diagram

V-200U

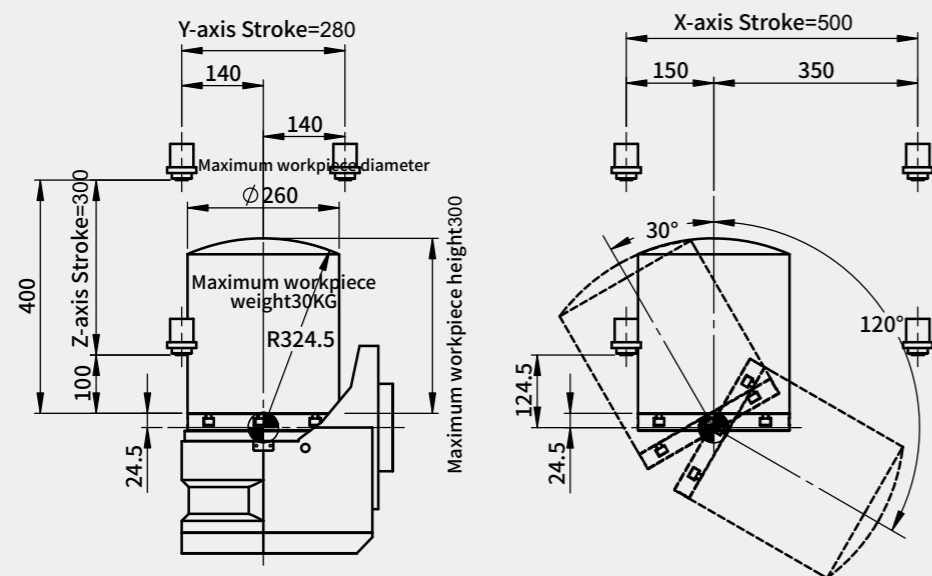

V-400U

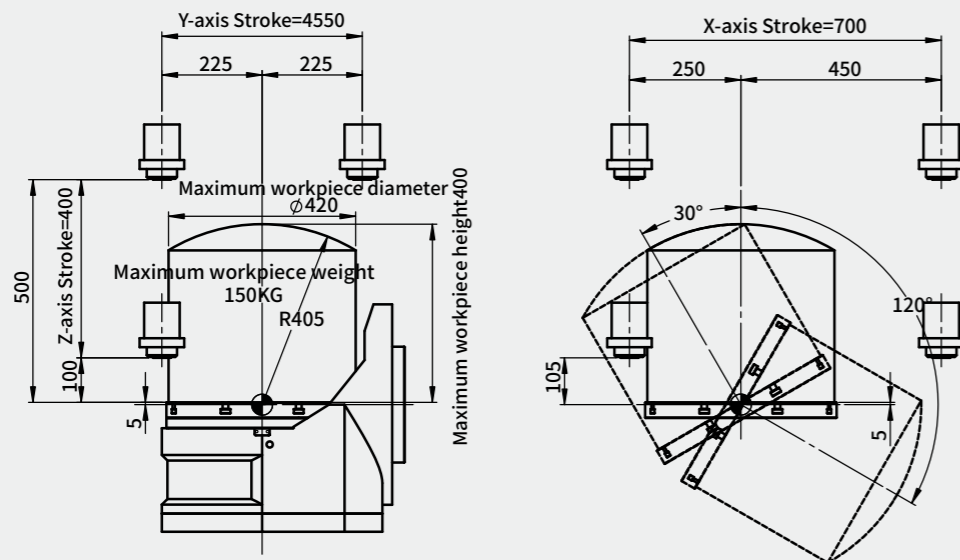

Outline Dimensional Drawing

V-200U

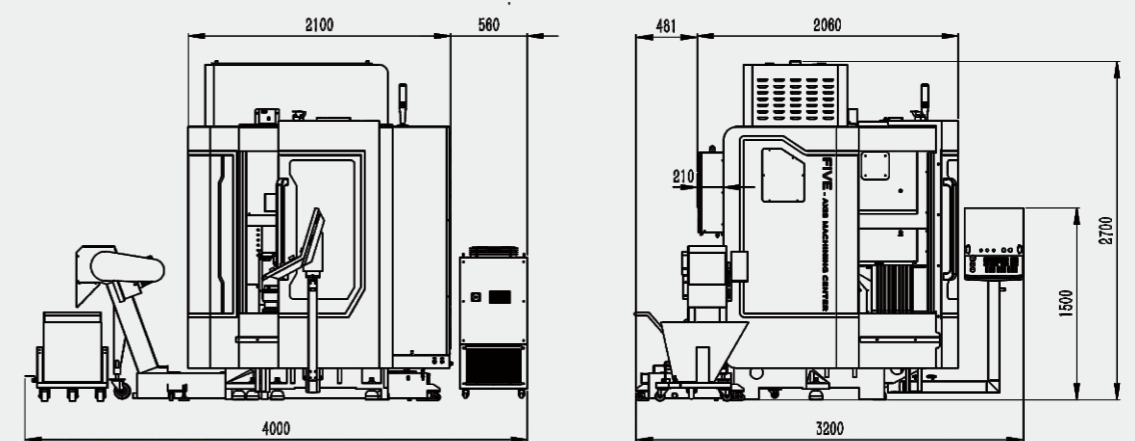

V-400U

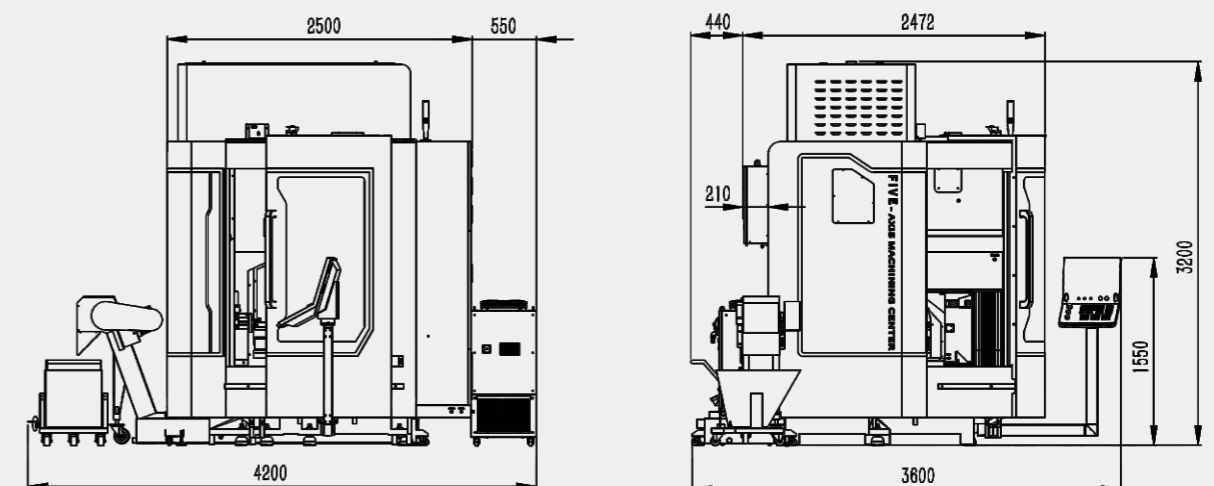

Features and Technologies

Structure and configuration

Optional and highlights

parameter and dimension

Five-axis Machining Center

V-500U/V-650U/V-800U

- ★ German technology plus high-precision DD direct drive rotarytable, original imported Siemens 5-axis CNC system
- ★ Combining industrial design elements and human-machine interaction, the overall appearance design of the machine is aesthetically pleasing and has a neat and reasonable layout of operating positions, enhancing the human-machine interaction experience



High speed
High precision
High efficiency

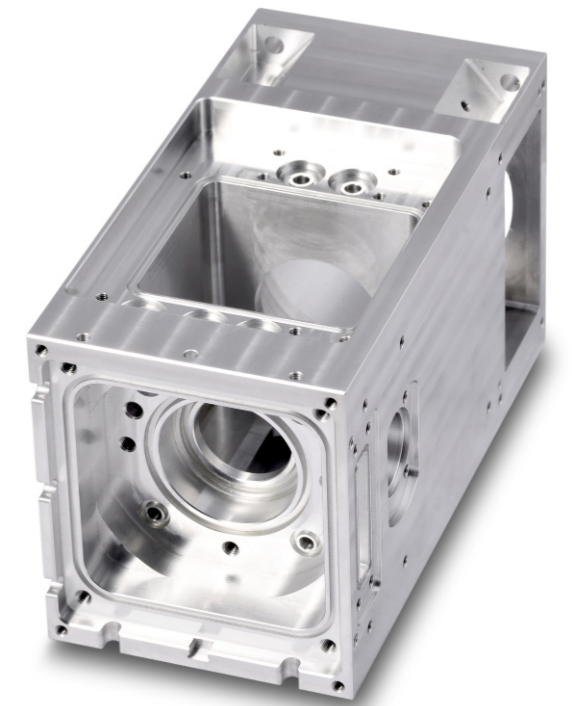

Collimating cavity

Diversified application fields

Impellers, Precision moulds, Medical device, Automated parts, Aerospace parts, Die casting



Impellers

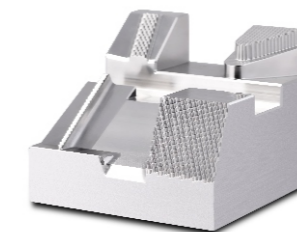

Combination pattern matching parts



locating ring



Car lamp pattern matching parts



medical parts

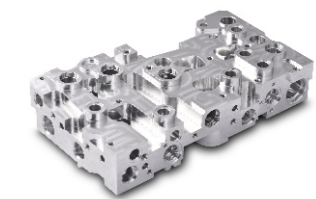

hydraulic valve body

Five-axis Machining Center

Technical Description of Equipment Structure

- ★ The main structure adopts moving beam gantry structure with high rigidity, the distance from spindle to cross beam is short, three axis independent operation, and the lathe bed is made of high-quality gray cast iron material, which has the characteristics such as small overall stress and deformation and strong vibration resistance
- ★ Y-axis dual screw dual drive structure technology for optimal dynamic response performance
- ★ German technology plus high precision DD direct drive rotarytable, A-axis dual torque motor dual drive technology, matched with high-resolution encoder, and the rotarytable body is designed with reasonable cooling channel to ensure the transmission accuracy and stability
- ★ The A/C is fixed in the base and operates independently. It is designed with high rigidity and high load-bearing capacity, which can meet the needs of heavy cutting

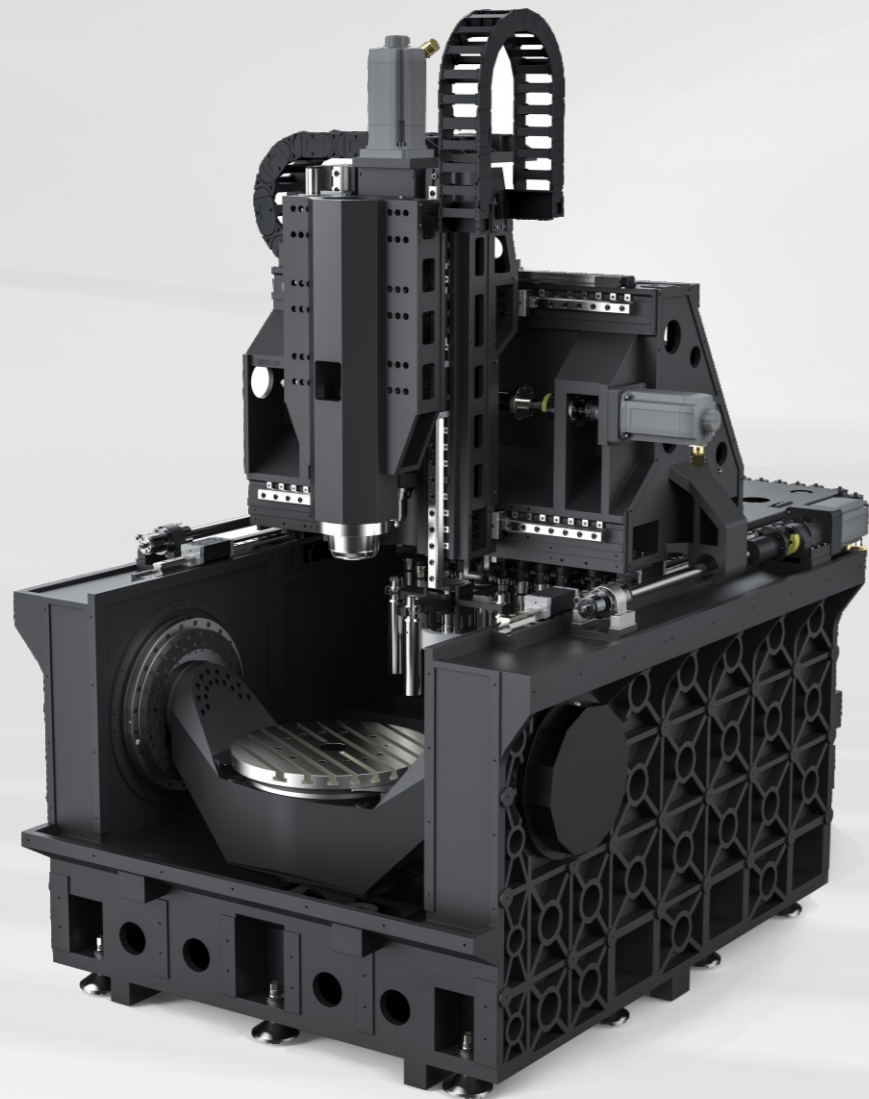

Five-axis Machining Center

Upmarket and safe processing configurations

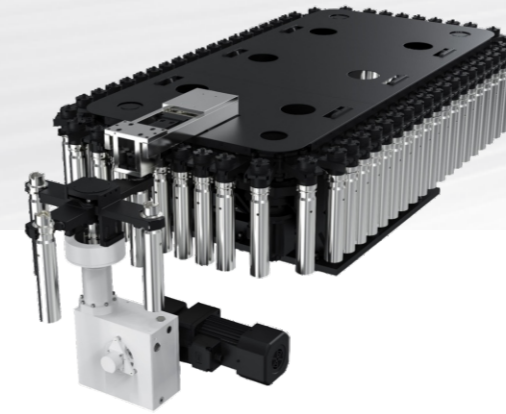

Configured with 40T chain tool magazine

- ▶ Maximum tool length: 300mm
- ▶ Maximum diameter : $\Phi 80\text{mm}/\phi 150\text{mm}$ (full magazine/vacant adjacent slot)
- ▶ Maximum tool weight: 8kg

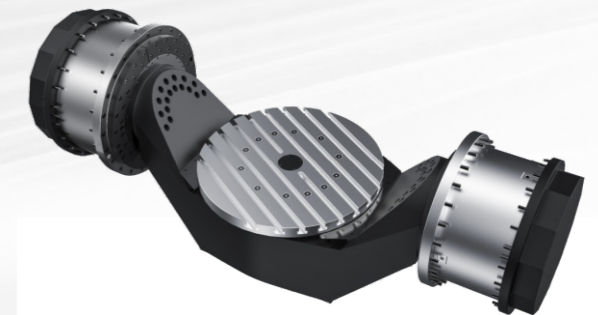

German technology plus high precision direct drive turntable

- 1** Independently designed A/C-axis cradle turntable structure, A-axis dual torque motor drive has greatly improved in rigidity and seismic resistance
- 2** The A/C axis is equipped with a large torque frameless direct drive motor, with a compact structural design that integrates the motor rotor with the rotary mechanism of the turntable, providing excellent transmission rigidity
- 3** The outer stator of the motor is cooled with coolant to ensure the thermal stability of the turntable
- 4** The maximum speed of the A/C axis can reach 50r/min

Optional spindle model

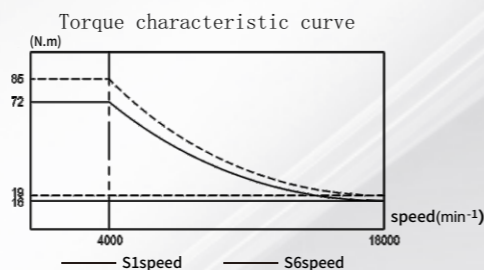
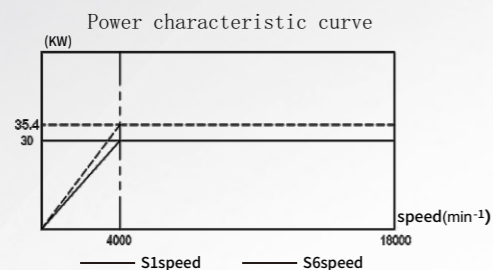
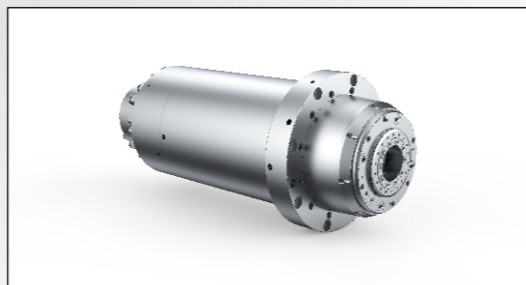

HSK A63 18000RPM 30/35.4KW 72/85Nm

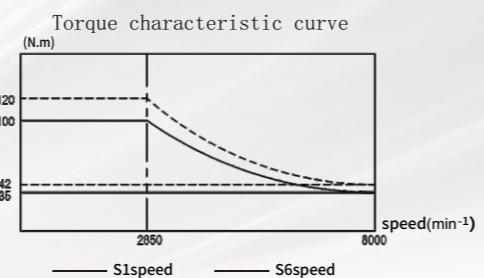
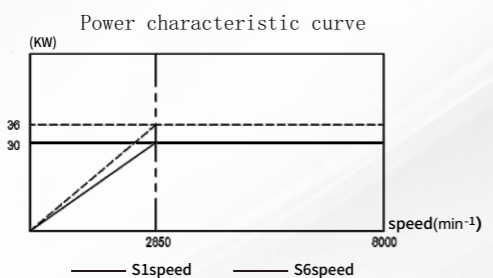

HSK A63 16000RPM 30/36KW 100/120Nm

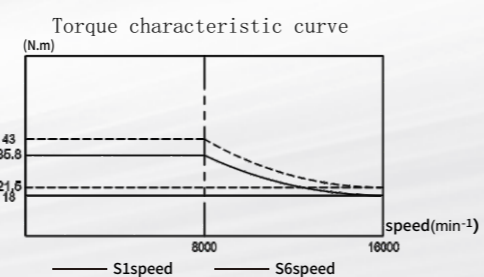
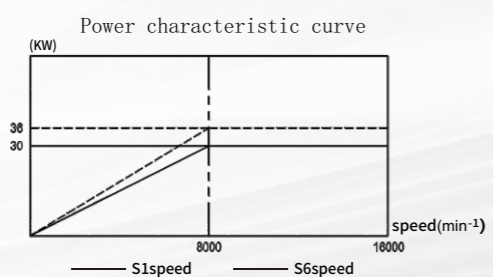

HSK A63 20000RPM 47.7/57.3KW 35/42Nm

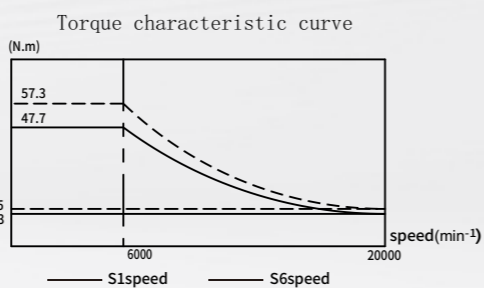
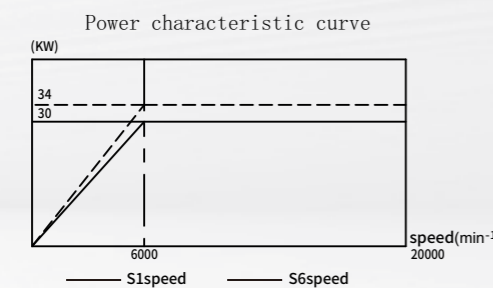

HSK A63 20000RPM 47.7/57.3KW 35/42Nm

V-500U machine range diagram/Outline Dimensional Drawing

Machine range diagram

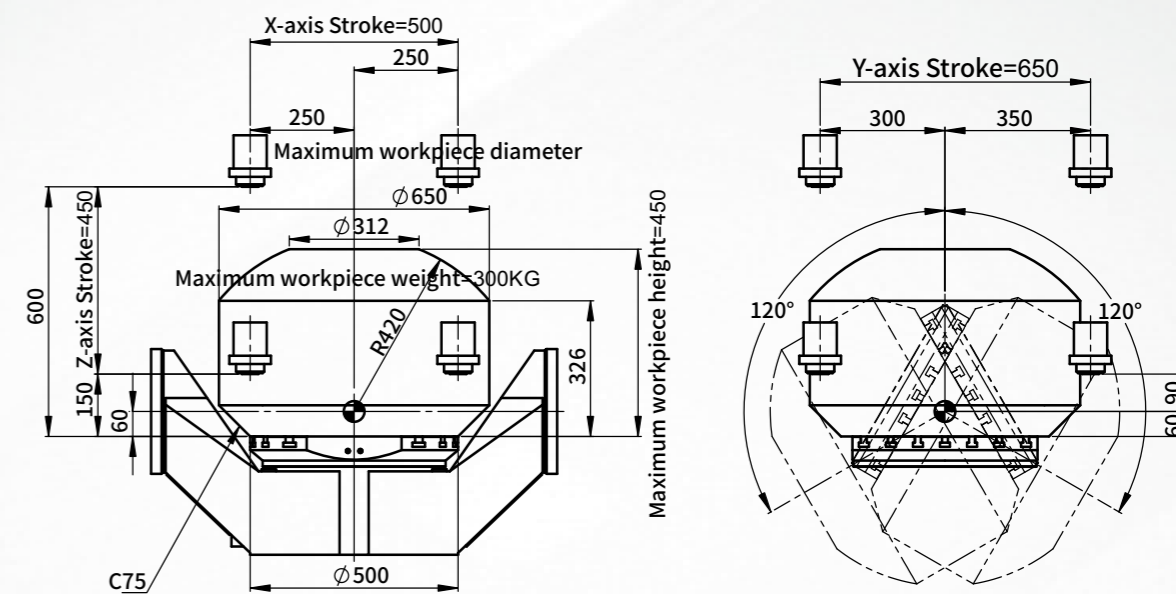

Outline Dimensional Drawing

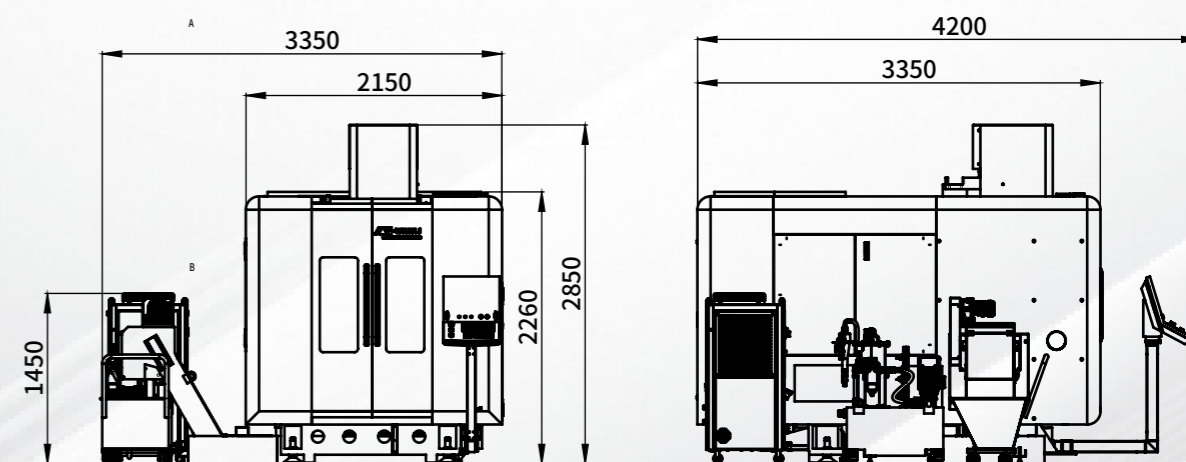

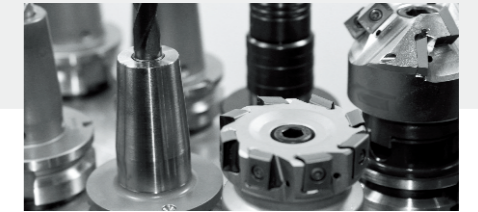

Technical Parameters

		V-500U	V-650U	V-800U
Stroke X/Y/Z	mm	500/650/450	650/800/500	850/900/550
A-axis Rotation range	°	±120	±120	±120
C-axis Rotation range	°	360	360	360
Distance from spindle nose to worktable	mm	150-600	150-650	180-730
Worktable size	mm	φ500*445	φ650*530	φ800*700
Maximum load of the worktable	kg	300	500	800
T-slot (number of slots - slot width*spacing)	mm	7-18*65	7-18*65	7-18*100
X/Y/Z-axis Fast moving speed	mm/min	36000	36000	36000
B/C-axis Rapid rotation speed	r/min	50/50	50/50	50/50
X/Y/Z-axis Positioning accuracy	mm	0.006/0.006/0.006 (VDI 3441)	0.006/0.006/0.006 (VDI 3441)	0.006/0.006/0.006 (VDI 3441)
X/Y/Z-axis Repeated positioning accuracy	mm	0.004/0.004/0.004 (VDI 3441)	0.004/0.004/0.004 (VDI 3441)	0.004/0.004/0.004 (VDI 3441)
A/C-axis Positioning accuracy	sec	5/5 (VDI 3441)	5/5 (VDI 3441)	6/6 (VDI 3441)
A/C-axis Repeated positioning accuracy	sec	3/3 (VDI 3441)	3/3 (VDI 3441)	4/4 (VDI 3441)
Spindle motor power	kW	30/35.5	30/35.5	30/35.5
Spindle motor torque(S1/S6)	N.m	47.7/57.3	72/85	100/120
Spindle speed	r/min	0~20000	0~18000	0~16000
Spindle taper	/	HSK A63	HSK A63	HSK A63
Tool magazine structure	/	Chain arm type tool magazine	Chain arm type tool magazine	Chain arm type tool magazine
Tool magazine capacity	T	40	40	40
Maximum tool weight	kg	8	8	8
Maximum tool length	mm	300	300	300
Maximum diameter (full magazine/vacant adjacent slot)	mm	φ80/φ150	φ80/φ150	φ80/φ150
CNC system	/	SiemensSINUMERIK ONE	SiemensSINUMERIK ONE	SiemensSINUMERIK ONE
Overall dimension of lathe (L*W*H)	mm	3900*3800*3200	4900*4200*3300	5100*4500*3400

All pictures and parameter configurations in this album are for reference only. The products delivered shall prevail. Our products are being constantly upgraded, and the above information is subject to change without prior notice.

Technical configuration

	V-500U	V-650U	V-800U
Cast iron housing	●	●	●
THK/INA roller guide rail	●	●	●
NSK high-speed screw (with hollow cooling or nut cooling)	●	●	●
DD direct drive turntable	●	●	●
Full protection under sheet metal cover	●	●	●
Intelligent operation panel (a 18.5" display)	●	●	●
HSK A63high-speed motorized spindle20000rpm	●	○	△
HSK A63high-speed motorized spindle18000rpm	▲	●	○
HSK A63high-speed motorized spindle16000rpm	▲	○	●
40Tchain tool magazine	●	●	●
60Tchain tool magazine	○	○	○
Frequency conversion water cooler with temp. of ±0.1° (spindle, turntable, screw)	●	●	●
Electric cabinet A/C	●	●	●
Scraper chip conveyor	○	○	●
Drum scraper chip conveyor	○	○	○
Chain plate chip conveyor	○	○	○
Automatic lubricating system	●	●	○
Gas circuit system	●	●	●
LED work light	●	●	●
Tricolor warning light	●	●	●
Safety door lock	●	●	●
External hand wheel	●	●	●
Power failure back-off protection device	●	●	●
Tool cutting & cooling system	●	●	●
In-machine chip flushing system	●	●	●
Air gun	●	●	●
Water gun	●	●	●
Siemens SINUMERIK ONE Five axis control system	●	●	●
HEIDENHAIN TNC640 Five axis control system	○	○	○
Linear grating rulers for three axes	○	○	○
BLUM setting gauge-setter	○	○	○
HEXAGON setting gauge-setter	○	○	○
Automatic calibration system of slewing center (Renishaw OMP400 probe, standard ball and calibration system)	○	○	○
Anti-collision system	○	○	○
Oil mist collector	○	○	○
Oil-gas lubricating system of spindle	○	○	○
CTS 2/3/5/7MPa	○	○	○
Virtual Lathe and Simulation System	○	○	○

● Standard configurations ○ Optional configuration ▲ Consultation required △ Not Supported

Five-axis Machining Center

Virtual Lathe and Simulation System

* Virtual Machine Tool Cutting Verification Process

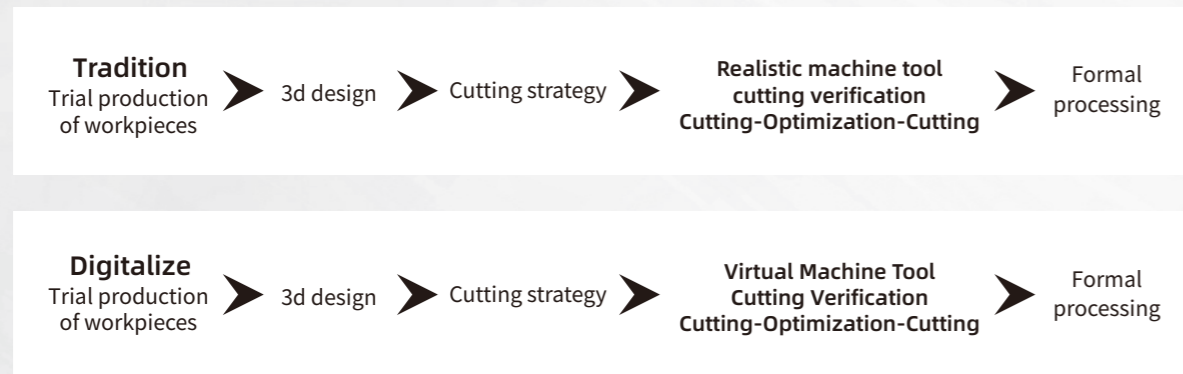

* Customer Value Reflected by Digital Native Machine Tools in Different Scenarios



Greatly improve the efficiency of workpiece trial production
 Shorten the trial production cycle of 30% of workpieces



Improve equipment utilization
 Equipment does not need to be shut down for trial production



Reduce training costs
 Avoid beginners using collision machines



Visualize providing cutting solutions and Real cutting time, cutting process.
 Improve sales winning rate

Five-axis Machining Center

SINUMERIK ONE Highlights

1 High-performance

- + Powerful multi-core UP technology
- + Due to the integration of S7-1500 PLC, the PLC cycle is 10 times faster
- + Two independent PROFINET networks

2 Security

- + SIMATIC S7 1500 Failsafe Function: Safety Logic
- + SINAMICS Safety built-in security motion monitoring

3 High efficiency

- + Top Speedplus: Faster mold processing
- + Intelligent Load Control
- + Interpolation car: complete turning on a milling machine to shorten the processing cycle

4 Flexible

- + New panel CNC for high-end compact models
- + Rich products: HMI, NCU, drives, and motors

5 Security

- + Protecting Data Security
- + Access and data acquisition management
- + Implementing security for new services and business models

